

Colibri

V 4.0

IGC APPROVED FLIGHT RECORDER



LX navigation d.o.o.
Tkalska 10
SI - 3000 Celje
support@lxnavigation.si

tel.: +386 3 4904670

fax: +386 3 4904671

<http://www.lxnavigation.si>

Content

1	Introduction	4
1.1	Basic principles	4
1.2	Hardware configuration	5
1.3	Colibri - Physical Details	6
1.4	Power requirements.....	6
1.5	The Colibri keyboard and display	6
1.5.1	The Keyboard and its functionality.....	6
2	Minimum preparation for an IGC flight.....	7
2.1	Task declaration	7
2.1.1	Task declaration procedure	7
2.2	Entering Pilot and Glider data.....	9
2.2.1	Pilot data	9
2.2.2	Glider data	9
2.3	Preflight check	10
3	Modes of operation	10
3.1	Powering up	10
3.2	Menu structure	10
3.2.1	GPS Mode.....	11
3.2.2	TP Mode	11
3.2.2.1	TP selection and navigation to TP.....	11
3.2.2.2	Editing TP data and the input of new data	12
3.2.3	Task Mode (for navigation only)	14
3.2.4	APT Mode	15
3.2.4.1	Airport Selection.....	15
3.2.4.2	Navigation to an airport.....	16
3.2.4.3	Near airport function.....	16
3.2.5	SETUP mode.....	16
3.2.5.1	Flight Recorder Setup	16
3.2.5.2	PILOT LIST	19
3.2.5.3	GLIDER LIST	19
3.2.5.4	TIME ZONE.....	20
3.2.5.5	UNITS.....	20
3.2.5.6	NMEA OUTPUT.....	20
3.2.5.7	COM. SPEED.....	21
3.2.5.8	PASSWORD.....	21
3.2.6	VIEW FLIGHT RECORDER	21
4	Wiring and installation	22
4.1	Wiring	22
5	Communication.....	24
5.1	PC communication.....	24
5.1.1	PC specifications	24
5.1.1.1	Use of laptops	24
5.1.1.2	Establishing CONNECT status	25
5.1.1.3	Downloading to a PDA	27
5.1.1.4	Communication with LX 5000/7000.....	27
6	Basic flight evaluation	28
7	Problems.....	29
7.1	INIT MEMORY procedure.....	29
8	Baro calibration procedure.....	29
9	Colibri USB Port.....	31
9.1	Installing USB driver	31
9.2	Data transfer through USB	33
9.3	Troubleshooting the Colibri/USB connection.....	33
10	Tree structure diagram	34

1 Introduction

The primary task of the unit is to produce a secure flight record containing GPS position, GPS altitude, pressure altitude and engine operation at pre-determined intervals for subsequent analysis. Additionally, a number of attractive and useful features are implemented to enhance the unit's capabilities. The flight recorder meets all IGC (**I**nternational **G**liding **C**ommission) requirements and has unrestricted IGC Approval with no limitations. Full details of the approval are listed in the FAI website (<http://www.fai.org/gliding/gnss/lxncolibri.pdf>). Chapter 2 of this manual contains a quick reference for pilots in a hurry while later chapters describe the many features and functions in greater detail.

1.1 Basic principles

The unit does not need any programming or initialisation to start recording, once the power is on and the antenna connected, the unit will start recording when one of the following conditions are met:

- When a ground speed of more than 20 kph (12 kts) is detected, or
- An increase of pressure altitude or climb, is detected.

Many of the recording parameters can be changed or implemented through the **Setup menu**, which are described in later chapters. Without an antenna connected, the unit will operate as a recording barograph.

Recorded data is downloaded using a PC or PDA and the corresponding program must be installed. All necessary software to achieve this is supplied with each instrument on a CD. While third party software exists to download the instrument, it is strongly recommended that the following programs from LX Navigation are used:

- For downloading with a PC - LXe
- For downloading with a PDA - ConnectLX

Note!

Colibri v4.0 is able to communicate with a PC via a USB port and for this purpose, a small mini **B type** connector is situated near the main RJ plug. When connected to a PC via the USB port, the unit is powered from the PC, making an external power supply un-necessary.

Warning!

When the USB port is connected, the GPS module is automatically disconnected to save power. Thus powering through the USB port during flight is not an option as the GPS will be inoperative. The main RJ plug **should be removed** before using the USB.

Important note!

The USB communication may not work on all computers and operating systems. It is essential that you follow the instructions for installing the USB drivers in chapter 8 very carefully.

The following description of the flight files is for information only and can be skipped by the non-technical reader. When a flight is downloaded, two files are generated, one with a **.LXN** extension and another with an **.IGC** extension. The **.LXN** file is a binary file while the **.IGC** file is text file and can be opened using a text editor. An example of the content of an **.IGC** file is shown below:

```
ALXNC3EFLIGHT:1
HFDETE120404
HFFXA100
```

```
HFPLTPILOT:ALES.KLINAR
HFGTYGLIDERTYPE:MOSQUITO
HFGIDGLIDERID:S5-3099
HFDTM100DATUM:WGS-1984
HFGPSGPS:JRC/CCA-450
HFFTYFRTYPE:LXNAVIGATION,COLIBRI
HFRFWFIRMWAREVERSION:3.0
HFRHWHARDWAREVERSION:2.0
HFCIDCOMPETITIONID:LXN
```

'A' record gives recorder 3digit IGC S/N
'H' record is the extended flight info

HFCCCOMPETITIONCLASS:STANDARD
I013638ENL

C1204041717391204040001002
C5100000N00818416ESCHAMEDE
C5108588N00756023ETSKSTART
C5208588N00756023TP001
C5208588N00856023TP007
C5100000N00818416ESCHAMEDE
C5100000N00818416ESCHAMEDE

'C' record lists the task declaration in the form:
Take Off
Task Start
Turnpoint 1
Turnpoint x
Task finish
Landing

LFILORIGIN0924405108590N00756026E
B0924405108590N00756026EA0021500375
B0924525108589N00756026EA0021500369
B0925045108590N00756026EA0021400379
B0925165108590N00756026EA0021500371
B0927045108590N00756024EA0021400371999
G1FFFFA7E810EA2A83B88847A3825C8331FEC65DF5

'B' records show time, position, pressure and
GPS altitudes, as well as optional records such as
ENL (Engine Noise Level)

'G' record (file integrity)

The **B record** contains following data:

- UTC time (hh,mm,ss)
- The GPS Coordinates (dd,mm.mmm) terminating with N(S) or E (W).
- The GPS status, an 'A' indicates a good fix while a 'V' indicates a bad fix
- GPS altitude (00371)in meters
- Pressure altitude (00214)in meters
- The example shows engine noise level (ENL) as the last 3 numbers; this record is set as required by the pilot and is not obligatory for pure gliders.

The **G record** is always the last record and is used exclusively for data security purpose. Flights without a valid G record will fail security and are not acceptable for FAI/IGC purposes.

The **.LXN** file type is binary and cannot be opened using a text editor. When using **LXe** or **ConnectLX**, the binary **.LXN** file will automatically be converted into an **.IGC** file.

IGC requires that some additionally programs are made available for flight recorder downloading and flight evaluation. These programs are mostly used by third party competition analysis software. These additional programs are available on <http://www.fai.org/glidning/gnss> and are also included on the CD supplied with every Colibri.

- IGC-LXN.DLL A Windows program running in conjunction with IGC-Shell
- DATA-LXN.EXE A DOS program for flight downloading
- CONV-LXN.EXE A DOS program which converts an **.LXN** file into an **.IGC** version
- VALI-LXN.EXE A DOS program which checks the data integrity of the **.IGC** file

However, LX Navigation strongly recommend that only **LXe**, **See You** or **ConnectLX** are used to download flight records from the Colibri.

1.2 Hardware configuration

The Colibri flight recorder contains the following sub-modules:

- A **GPS** receiver with antenna
- A **microprocessor** with volatile memory that is backed up with a 3.0V Lithium cell. The memory battery life is expected to be **at least five years**, and it is recommended that the battery is replaced after this period. Battery replacement can only be carried out by an authorized LX service station as the unit will require resealing after the battery replacement.
- A **pressure sensor** which measures pressure altitude based on the International Standard Atmosphere, 1013.2 HPa
- A **physical and digital secure device**. The unit is sealed with both a physical seal placed over one of the case securing screws, and an electronic seal that is broken if the case is removed. If a non authorized person opens the unit, then both the physical and electronic seals will be broken and the message **SEAL NOT VALID** will appear after power on. While the unit is fully operable in this

condition, any flight record downloaded will be not be secure and is not acceptable for FAI/IGC purposes. Only an authorized LX Navigation service station can restore the seals.

- An **engine noise level (ENL)** sensor for the detection of engine noise in self launched and self sustainer gliders. The ENL is enabled as a factory option in all units.
- A **power and PC** plug of RJ type
- A mini 'B' **USB** port to communicate with a PC which also powers the unit while the port is in use.
- A **suitable** mounting bracket for easy installation in the glider.

1.3 Colibri - Physical Details

At the present time, the Colibri is the smallest IGC approved flight recorder available on the market, and is easily installed. It can also be installed on the instrument panel where it can be used as an in flight GPS navigation aid.

Dimensions.....52x100x32mm
Weight.....220 g

A suitable mounting bracket is supplied to facilitate installation in the glider so that it is easily removable when required.

1.4 Power requirements

The unit will accept DC power from **8V DC up to 24 V DC** via the 6 pole RJ type connector. Power consumption is about 100 mA at 12V. When the USB is used, the microprocessor is powered directly from the PC and the GPS receiver is automatically switched off to conserve power.

1.5 The Colibri keyboard and display

The unit is operated via a membrane keyboard with 9 buttons arranged in three rows of three. A two line, eight character dot matrix is positioned above the keyboard. While the display is temperature compensated, it is recommended to keep it out of direct sunshine when the temperature could easily exceed 70 °C causing the display to darken. The phenomenon is reversible and will not cause permanent damage.

1.5.1 The Keyboard and its functionality

- **Two horizontal arrows (◀ ▶)**, these buttons are used to change the mode of operation and therefore they have the highest priority. During the editing procedure, they can be used to retrace the cursor to correct mistakes.
- **Two vertical arrows (▲ ▼)** are used to scroll vertically in a specific mode such as selecting turn points.
- **Enter** is used either as a confirmation key, or is used to start an input or selection.
- **ESC** is a multifunction key:
 - It will call the navigation pages in the TP, TSK and APT menus
 - It will confirm the whole row when in edit mode (the edit mode is indicated by a blinking cursor), replacing multiple pressing of the enter button
 - It closes the edit procedure
- **EVENT/PC** is a multifunction button; during flight it will activate the event marker function, while on the ground it will connect the unit to a PC.
- **DECL** is a single function button which will go directly to the task declaration screen.

- **PILOT/GLIDER** A single press will enable pilot selection or the adding of a new pilot. A double press allows glider type selection or the adding of a new glider type. This feature simplifies the programming of units used in a Club environment as the Colibri is able to store up to 100 pilot names and 30 glider types.

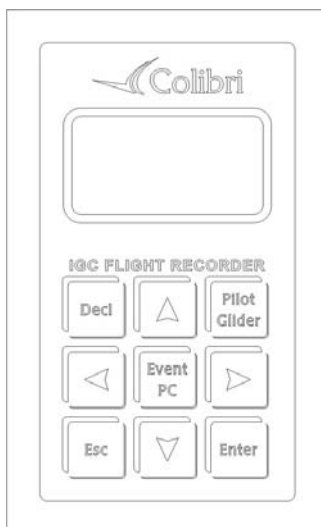

2 Minimum preparation for an IGC flight

This chapter is intended as a quick reference for the busy pilot. The succeeding chapters will give a more detailed explanation of the procedures.

To meet the IGC requirements for a badge or record flight, the following inputs are mandatory:

- Task declaration
- Pilot and glider identification

Note!

It is strongly recommended that the unit is **powered up approximately 5 minutes before take off**. This will ensure that GPS is locked onto the satellites prior to take off, and that the barogram will have a base line. After landing wait until the **SECURITY CHECK** message appears on the display and switch the unit off after the message has disappeared. If the SECURITY CHECK message was not seen when it appeared after landing, a check that the flight has finished and that the security check has been done, is that the status **STOP** will be seen in the GPS mode menu. If the unit is powered off immediately after landing, then the landing base line will be lost, but not the flight log or data security. The unit will go through the SECURITY CHECK procedure after next power on.

2.1 Task declaration

Pressing the **Decl** button will open a dialog allowing the declaration of the task which it is intended to fly. Declaration is only possible if the **turn points** or task it is intended to declare are already stored in the Colibri memory. If the required turn points are not stored in the unit, then they must either first be programmed through the TP menu, or the declaration loaded via a PC, using the LXe, See You, or ConnectLX programs.

2.1.1 Task declaration procedure

Reference should be made to the subsequent chapters if any of the procedures outlined below are not fully understood.

- Press **Decl** button and select **COPY, EDIT or DELETE** with the vertical arrows **▲▼**. **COPY** is selected if the task that it is required to declare is one of the possible 100 tasks already programmed in the unit. Select **EDIT** if you want to modify an already declared task. **DELETE** will delete the last

declared task leaving a completely empty task framework to re-enter the new task. Deleting the last declared task has no effect on any tasks that might already be stored in the task memory.

A declared IGC task must have the following structure:

- **Take off** (T)
- **Start** (S)
- **Turn points 0-9** (P)
- **Finish** (F)
- **Landing**

The functions SELECT, INSERT and DELETE of turn points will help you to modify an already declared task.

- **SELECT** will **replace** the turn point with a new one
- **INSERT** will **insert** a new turn point (TP) one step towards the finish. For instance, using insert on point 3 will produce point 4 and all remaining points will be shifted towards the finish and landing.
- **DELETE** will **delete** TP

Selecting a take off point will be automatically enter the same point as the landing point. If this is not the case, use select to replace the landing point

Note!

The task declared in this menu will be automatically be copied into the TSK mode and is immediately ready for navigation.

Once a task has been declared, it will remain in the unit until a new declaration is made.

Once all the TPs have been entered, the procedure is closed by pressing **Esc** when if the procedure has been done correctly, a very clear message and a “beep” will show:

TASK
DECLARED

If the declaration procedure is not terminated by pressing **Esc**, the unit will activate an audio alarm after 30 seconds and display the message:

DECLARE
TASK? Y

Selecting ‘Y’ will finish the declaration procedure while ‘N’ will reopen the edit dialog.

Note!

Task declaration can also be implemented from a PC or PDA, using the “Flight info” data transfer procedure.

2.2 Entering Pilot and Glider data

2.2.1 Pilot data

Pressing the **Pilot/Glider** button once will show the last active pilot. Use the vertical arrows ▲ ▼ to select, and **Enter** to confirm, a new pilot. If the required pilot’s name is not already programmed, then select PILOT ADD and press **Enter**.

PILOT
ADD

Enter the new pilot’s name and press **Esc** and confirm with ‘Y’.

SAVE? Y
JOHN

Note!

Separate first name and surname using a **space** or **_**. When data is transferred from a PC or PDA using “Flight info”, a new pilot name will be added automatically. There is no edit procedure; use SETUP to edit or remove pilots. A maximum of 100 pilot names can be stored.

2.2.2 Glider data

Pressing the **Pilot/Glider** button twice will show the actual glider selection, simple finish with **Esc** if correct, or select the glider using ▲ ▼ and confirm with **Enter**. If the glider type isn’t present, then select GLIDER ADD to **add** a new one.

GLIDER
ADD

Enter the glider type, confirm with **Esc**, input REG.NUMBER, COMPETITION NUMBER and COMPETITION CLASS. Finish the procedure with **Esc** and confirm with **Y** if all the data is correct. There is no edit function in this menu. To edit or remove glider data use **SETUP**.

SAVE? Y

Note!

To scroll through the glider data use the horizontal arrows ◀ ▶

2.3 Preflight check

- Check task declaration using edit function and modify the task if necessary
- Select pilot and glider
- Check flight recorder settings and adapt, if necessary (check ENL on in motor gliders or turbos!)
- Switch the unit on approximately 5 minutes before take off

3 Modes of operation

This chapter describes the many features of the Colibri . It is recommended that all users read this part carefully.

3.1 Powering up

There is no **ON/OFF** switch on the unit. Immediately after connecting the power, initialisation will follow and will indicate the:

- Serial Number
- Active pilot name
- Airport data base version
- Flight recorder memory capacity

Note!

The memory capacity indicator does not show free memory, but the recorder's total **memory capacity** in hours that is available for flight records. The total memory capacity depends on settings only, the main one being the recording interval; the shorter the recording interval, the less total memory capacity available. The total memory capacity displayed will not reduce as flight data is stored. Once the memory capacity is filled with flight data, the oldest data is erased and the new data recorded. For instance, if the total memory capacity is shown as 71 hours, then the unit is storing the last 71 hours of flight data, and flights made more than 71 hours ago will have been automatically deleted without any warning.

3.2 Menu structure

There are six modes of operation; the selection of which are controlled by the horizontal arrows (◀ ▶). The six modes are:

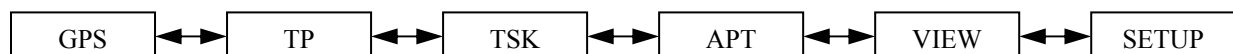

3.2.1 GPS Mode

Note!
There are no user inputs possible in this mode

To scroll through the mode use the vertical arrows ▲▼.

- **GPS** Status
- **LAT** and **LON** indicator
- **Pressure altitude** indicator
- **Time** (local) and **date**
- **Battery** voltage indicator and **DOP** (dilution of precision)
- **Flight recorder** status: **LOG**, **STOP**, **RUN**, **NEAR** (if near to the TP), **INSIDE** (if inside of sector), and **MEMory** capacity in hours

3.2.2 TP Mode

The unit is able to store up to 600 turn points and 100 tasks. Turn points and tasks may be entered manually or by transfer from a PC.

- **Manual** input of turn point name and GPS coordinates.
- **Transfer** of .da4 files from, PC (LXe,SeeYou, Strepla), PDA (ConnectLX,,Downloader), LX 5000, LX7000,LX 7007.

Note!
The .da4 extension is the LX standard format developed for use with all LX instruments. One .da4 file can store up to 600 turn points and 100 tasks. See next chapters for details.

3.2.2.1 TP selection and navigation to TP

After selecting the TP mode with the horizontal arrows (◀▶), the last selected TP will be ready for navigation. Initially, up to 8 characters of the assigned name will be displayed.

TP:
NAME

After approximately one second the display will change to the first navigation page, where the **first 4** characters of the name and basic navigation data will be displayed (**t**...**track**, **b**...**bearing**, **k/m**... **distance**).

123°t CUND
126°b235km

Pressing **Esc** will change to a second navigation page in which the ground speed replaces the name of the TP.

123° t 134 kh
126° b 235km

kh..... Grund speed

A further press of **Esc** will display the wind calculation.

Wind
234 ° 24 kh

The **wind calculation** is based on measuring drift while climbing in a thermal. Two full circles are necessary before the wind can be displayed. The procedure is fully automatic and requires no pilot manipulation other than to try and keep the speed constant while thermalling.

Note!

To scroll through the stored TPs use the vertical arrows ▲▼. The longer the press, the faster the scrolling. The TPs are always sorted alphabetically.

3.2.2.2 Editing TP data and the input of new data

Pressing **Enter** when the TP mode is selected will open the following menu. Use the vertical arrow keys ▲▼ to scroll through the following options.

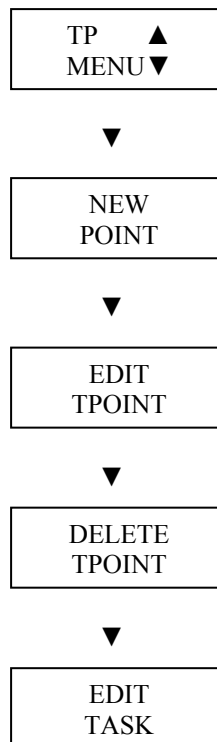

Note!

The tasks stored in the Colibri memory can only be **accessed and edited** from this menu; the TSK mode is used exclusively for navigation.

3.2.2.2.1 Input of a new TP

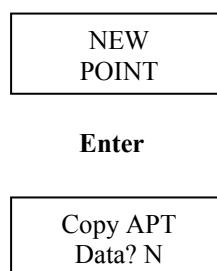

Selecting 'Y' enables an airport already in the APT menu to be copied into the TP library as a new TP, while selecting 'N' enables the input of a new TP. See the chapter on APT for details how to select an airport.

- **Manual input of a new turn point**

NAME XXXXXXXX

Use ▲▼ to scroll through the alphabet and confirm each input with **Enter**. A maximum of eight characters can be used in the TP name. Once the name is complete, press **Esc**.

LAT N00 00.00

Use ▲▼ to input LAT, confirm each input with **Enter** and finish with **Esc**.

LON E 000 00.00

Use ▲▼ to input LON, confirm each input with **Enter** and finish with **Esc**.

ALT 0001m

Use ▲▼ to input of TP elevation, confirm with **Enter** and finish with **Esc**.

Data OK? N

Selecting 'Y' and pressing **Enter** will store the TP data while selecting 'N' and pressing **Enter** will restart the procedure to allow the correction of wrong inputs.

3.2.2.2.2 *Edit TP*

TP data can be modified at any time by use of the EDIT TPOINT function. The name, GPS coordinates and elevation can all be changed and stored.

Note!

If during editing, a complete row of data does not require to be changed, simple confirm with **Esc** rather than pressing **Enter** 8 times.

3.2.2.2.3 *Delete TP*

Selecting DELETE TP? and pressing Enter will display a 'Y'. If the 'Y' is confirmed by pressing Enter, the selected TP will be deleted permanently.

3.2.2.2.4 *Edit Task (modification and creation of a new task)*

As previously mentioned, the unit has the capacity to store up to 100 tasks in .da4 format; each task consisting of up to 10 points including the start and finish points.

Note!

The .da4 format does not accept take off and landing points, only **start, turn and finish points**. It follows that a task created in this menu will only consist of start, turn and finish points. If this task is subsequently declared using the **Decl** function, then the take off and landing points are automatically inserted by copying the start and finish points. If this is not correct, then the declaration will have to be manually edited to reflect the situation.

While a completely new task can be created using of this menu, it is normally much quicker to copy another task and then modify it, restoring it under a new task no. Another solution is transfer a **.da4** file from a PC, PDA or LX 5000/7000. However, it should be noted that if a **.da4** file is transferred using a PC, PDA or LX 5000/7000, then the original **.da4** file in the Colibri is **overwritten** and all TPs and tasks will be replaced by those contained in the new file.

Note!

It is not possible to navigate using the task from this menu; the TSK mode should be used to navigate.

After selecting EDIT TASK and pressing **Enter**, using the vertical arrows ▲ ▼ will scroll through the task numbers.

TSK 00
4pt 198 km

The above screen indicates that the selected task is number 00 (00 up to 99 are possible), contains 4 points and is 198 km long. On pressing **Enter**, the first point (0) is ready for editing.

Note!

Point 0 is always the start point, and not the take off point.

Select the point it is wished to edit and press **Enter**:

INSERT POINT, will insert a new point one position higher than the selected point (for instance if INSERT is placed on TP3, the new point will be on position 4 and all remaining points will be shifted along one.

DELETE POINT, will delete the point from the task, but not from the TP library

SELECT POINT, will replace the point with another selected from the TP library

Note!

Use of the SELECT and INSERT functions will require TP selection as outlined below:

TP NAME

Replace the stars with the characters of the TP name, confirming each one by pressing **Enter**. If, for example, the first two characters are replaced by characters, then by terminating the process by pressing **Enter** twice more and accepting the stars, using the vertical arrows will permit scrolling through all the TP names in the unit starting with the selected first two characters.

3.2.3 Task Mode (for navigation only)

Note!

There are no user inputs possible in this mode. Its only function is to assist in task navigation, and the **declared task** will automatically be selected for navigation. If it is required to modify the task in flight, then it has to be done through the **Declaration** mode.

The task has following structure:

- **Take off point (T)**
- **Start (departure) point (S)**
- **Turn points (P)**
- **Finish point (F)**
- **Landing (L)**

The declared task can be checked before take off by scrolling through the task turning points using the vertical arrows ▲ ▼. Once movement of the glider is detected, the unit will automatically change to **Start point (S)** and will give navigational information to reach the departure point. An acoustic signal sounds when the glider enters the Start sector. The sector geometry is defined in SETUP/LOGGER SETUP/OBS.ZONE

Note!

If the pilot decides to start, then by pressing the down arrow ▼ the unit will change to TP1. This change over will happen whether or not the pilot is still in the start sector. If the pilot elects not to start at this time, the unit will continue to give navigational information to the Start point. On reaching the subsequent TPs, an **automatic change** over will follow once the TP sector is entered. A **manual** change over to the next TP, even if out of sector, can be made at any time simply by pressing the down arrow ▼.

Pressing **ESC** at any time will recall additional navigation pages and wind indicator, exactly the same as in TP mode.

Note!

During flight it is possible to modify the task at any time by using **Declare**. Any changes made during flight will not affect the declaration already stored in the IGC file

3.2.4 APT Mode

The APT(Airport) database memory of the Colibri can store up to 4200 airfields. The only PC program which is able to transfer APT data to the Colibri is LXe. The APT data base is supplied free of charge and is available at www.lxnavigation.si. Once the database is loaded into the Colibri, there is no edit function. This means that if the airport data needs to be modified, it can only be done in a PC and the new database transferred to Colibri.

Note!

The APT mode has two main functions; navigation to an airport, and selection of near airports.

3.2.4.1 Airport Selection

Press **Enter** and the following dialog will open:

APT ****

After replacement of **all four** stars with an ICAO **airport international code**, the airport will be selected directly. If the airport has not been assigned an ICAO code, or the code is not known, then an alternative method of selection must be used using the country and the airfield name. When the four stars are displayed, either press **Enter** four times or **Esc** once, when an alphabetical country list will be displayed.

APT ****
AUSTRIA

Use the up and down arrows ▲ ▼ to scroll through the countries and once the correct country is displayed, press **Enter**.

APT ****

Replace the stars with the first letters of the airport name. If more than one airport with the same first letters is found, then use the up and down arrows ▲ ▼ to scroll to the correct one. If no input is made and **Esc** is pressed, then it is possible to scroll through all airports of the selected country.

Note!

Management of the navigation pages is identical to that used in the TP mode. Pressing **Esc** will change to the next navigation page at any time.

3.2.4.2 Navigation to an airport

The same navigation features as in the TP mode are offered.

3.2.4.3 Near airport function

The unit is continually calculating the distances and bearings to the nearest airports.

Note!

The nearest airport is the current position is shown by pressing the up arrow ▲. Pressing the down arrow ▼ will scroll other near airports in increasing distance from the present position. Once an airport is displayed, pressing Enter will display all the navigation data to that airfield. If your destination is not in the list, then it will be necessary to reactivate the near airport function.

3.2.5 SETUP mode

This mode enables the programming of all the instrument settings.

3.2.5.1 Flight Recorder Setup

3.2.5.1.1 Record interval

This paragraph allows the pilot to select his preference for recording intervals..

Note!

The record interval selected has an effect on the memory capacity; the upper limit is 60 seconds and it can be reduced down to 1 second. A 60 second interval will give a memory capacity in excess of 450 hours while a 1 second interval will reduce it to **about 8 flight hours** of memory capacity. The suggested interval is between 4 and 10 seconds.

NORMAL: selects recording intervals under normal conditions (it is recommended that recording intervals of less than 4 seconds are not used)

NEAR TP: selects recording intervals automatically selected when close to a TP

NEAR RAD: selects recording intervals when near the edge of a TP zone

PEV INT: selects recording interval when **Event** marker input is activated (keyboard or external)

PEV FIX: selects number of additional fixes or records when the Event marker is activated

K-RECORD: will select record intervals for additional records when enabled such as J-records, see 3.2.5.1.5.

A NOT PROG message means that there are no additional records enabled in the J record setup. This feature is useful for recording of non critical data and therefore longer intervals can be used.

3.2.5.1.2 Observation zone

Specific configurations can be defined for departure/start zones, turn points zones and finish lines.

3.2.5.1.2.1 OBServation ZONE Template

Two types of zone are selectable as a default option:

- Photo Zone, which is the traditional FAI zone of 90 degrees and 3km radius.
- 500 m cylinder

The selected setting will be then be set for departure, turn point and finish zones.

3.2.5.1.2.2 Input of specific zones

By using this menu it is possible to define specific sectors for departure, turn points and finish zones separately. The parameters to be defined are:

- Orientation
- Two angles
- Two radius

START ZONE

Hdg (Orientation of the start zone):

- NEXT, orientated to the next turn point
- 1TPR, an arc is drawn from the first turn point through start point
- FIX, user selected value for orientation which is set in the next operation

Once the orientation has been defined, press ▼ to continue with the creation of the start sector.

a 12 defines orientation and is set to AUTO for NEXT and 1TPR. If FIX has been selected, then the orientation of start sector can be set in degrees independent of the first track..

a 1 defines the first angle, the input of which corresponds to ½ of the desired angle. eg 90° will define a half cylinder.

r 1 defines the radius of the sector a1, set above.

a 2 is the second angle

r 2 is the second radius

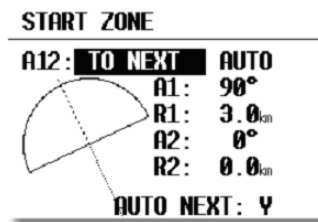

a 1= 90

r 1= 3km

Note!

When defining an arc with the 1TPR option selected, **a1** has no effect on the resultant zone, **r1** will define arc length, **a 2** has no effect, and **r2** defines sector depth.

POINT ZONE

Settings made under this option are valid for all turn points except start and finish. The basic principle is the same as described above, except that the orientation (Hdg) has following options:

- STR., to start sector or line
- FIX, allows user defined value to be set
- SYMM., symmetrical to bisector of the inbound and outbound legs
- PREV, to previous turn point
- NEXT, to next turn point

a 12 (orientation) is defined automatically (AUTO) with all options except FIX.

Angle and radius are set as described in the start sector above.

Example: This describes the most complex sector where all parameters are used: combining a photosector with a cylinder (sometimes referred to as a 'thistle')

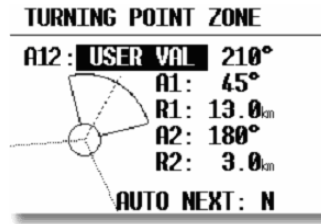

FINISH ZONE

Hdg (Orientation):

- LAST, orientated to the last turn point
- FIX, user value

a1, r1, a2 and r2 are defined as described previously.

Note!

For ease of programming, it is recommended that the zones are defined using the LXe PC program and then transferred to the Colibri.

Exsample:

Definition of an arc in LXe

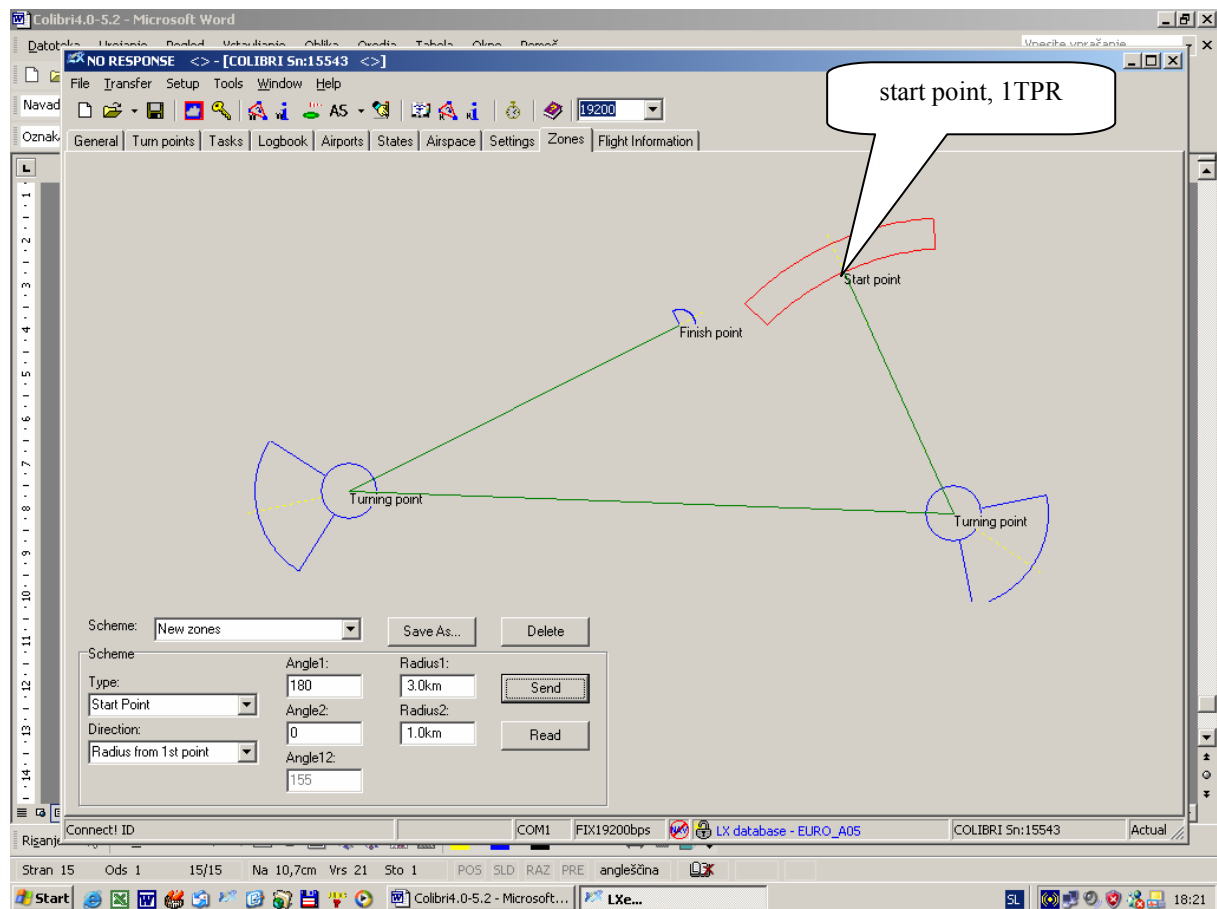

3.2.5.1.3 *OBS.ZONE BEEP*

The unit will produce a “beep” audio signal once the sector is penetrated. The duration of this audio signal in seconds can be defined and will be the same for every sector.

Note!

The audio signal is automatically inhibited for the first 3 minutes after takeoff to avoid distraction should the start zone be penetrated while on tow.

3.2.5.1.4 *I-RECORD DATA*

This input defines which additional records will be added to the IGC file. This facility is an advanced feature and it is recommended that it is not activated unless the composition of IGC records is fully understood. The exception is the **ENL** (engine noise level) function which should be activated in self launching and self sustaining gliders.

GSP, recording of ground speed

TRT, track

WDI, wind direction

WVE, wind speed

ENL, engine noise level (obligatory **Y**, for motor gliders)

3.2.5.1.5 *J-RECORD*

These are additional records which will be recorded according to the K-record interval setting. Again, activation of J records is not recommended unless they are fully understood. The same parameters as in I-record can be enabled

Note!

Adding additional I and J records will reduce the unit’s memory capacity. They are both advanced functions and should only be activated if the user fully understands IGC records. The exception is the **ENL** (engine noise level) record which should be set in self launching and self sustaining motor gliders.

3.2.5.2 **PILOT LIST**

The unit has the capability to store up to 100 pilot names. A manual input of a new pilot’s name is possible in this menu after pressing the **PILOT/GLIDER** key. Furthermore, when **Flight info** data is transferred to the unit from LXe, a new pilot will be added automatically. On pressing **ENTER**, the following options will be presented:

- **PILOT SELECT**, enables the selection of the active pilot
- **PILOT NEW**, adding of a new pilot, identical procedure as under **PILOT/GLIDER** key
- **PILOT EDIT**, to edit pilot data, this function is not available under **PILOT/GLIDER**
- **DELETE PILOT**, the selected pilot will be deleted, not possible under **PILOT/GLIDER**

3.2.5.3 **GLIDER LIST**

Very similar to pilot list, the input of up to a maximum of 30 different glider types is possible. There are two additionally actions which are not found under **PILOT/GLIDER**:

- **EDIT GLIDER**
- **DELETE GLIDER**

Edit and delete are available only in this menu; they are not available under **PILOT/GLIDER** key.

3.2.5.4 TIME ZONE

UTC (GMT) offset to give local time.

Note!

UTC offset will not affect the time recorded in the IGC-file, which will remain at UTC at all times.

3.2.5.5 UNITS

The unit can be programmed to show navigation data using all known units which are generally used in aviation.

Note!

Resetting the units in this menu will not have any effect on the recorded data.

3.2.5.6 NMEA OUTPUT

As the unit has a built in GPS receiver, it is capable of driving other vario or navigation systems which do not have a GPS receiver. The data is sent in the NMEA international format. The most common used data sentences, GGA and RMC, are active by default. This means that each Colibri is automatically sending this data at all times. To simplify the procedure for the pilots, two pre-configured sets of data can be selected; the third option enables specific NMEA sentences to be selected.

- **STANDARD:** The GGA and RMC are enabled
- **CUSTOM:** All possible data sentences can be individually selected
- **POCKET PC:** Those data sentences that are required to operate SeeYou Mobile, Navigator or Winpilot can be selected.

The table below may help in selecting the correct NMEA sentences.

Colibri NMEA	Standard	Pocket PC	Custom	Disable all

Connected unit				
LX 160/160s/i			GGA,RMC,RMB	
LX 1600	X			
LX 7000 basic*	X			
LX 7000 pro igc				X
LX 7007 pro igc				X
Pocket PC		X		

*If an LX 7000 Basic with **GPS option** is used, then use the LX 7000 pro igc settings.

Note!

It is strongly recommended that only those sentences actually needed are selected, otherwise it is possible that may overload the receiving unit.

3.2.5.7 COM. SPEED

The **COM. SPEED** defines the communication speed between the Colibri, PC, PDA or another LX device. The factory default setting is 19200 bps.

Note!

Changing the **COM. SPEED** has no effect on the transmission of NMEA sentences, NMEA data will always be sent at 4800 bps. If problems are experienced transferring data to or from the Colibri, then it is recommended that **COM.SPEED** is reduced to 9800bps in both the Colibri and the PC. The selected data rate must always be the same in both the Colibri and the PC.

3.2.5.8 PASSWORD

The normal password is **96990**

If **99999** is selected, then all flight records within the unit will be deleted.

3.2.6 VIEW FLIGHT RECORDER

All stored flights can be examined without being transferred to the PC. To select a flight of interest, use the Up/Down arrows ▲▼. The flights are identified by their date; the last flight is always at the top of the list with flight number '0'.

Note!

The **VIEW** mode is not active during flight (specifically when the unit is in the **RUN** mode)

On pressing **Enter**, the following flight statistics data is available:

- **TAKE OFF:** Take off time
- **LANDING:** Landing time
- **DURATION:** Duration of the flight, from take off until landing
- **DATE:** Date of flight
- **TASK STAT.:** Task statistics available after pressing **Enter**

Note!

Task statistics are available only if a task was declared. If the task was modified during flight, the statistics data will be based on the declared task and not on the real flown task and will be therefore be wrong.

After pressing **Enter** on **TASK STAT**, there will be delay of some seconds while the unit makes a calculation before displaying:

- **Tsk.dist:** Task distance
- **FINISHED:** Confirms a correctly flown task with no missing points
- **V:** Average speed on task
- **NoFINISH:** Indicates that there is a problem with the task; some turn points or finish are missing
- **Vario:** Vario average and percentage of time spent climbing
- **Track d.:** Actual distance flown

4 Wiring and installation

As previously mentioned, the unit is very small is capable of being installed in many places in the glider. When deciding on where to install it, one factor is whether or not the unit will be used in flight to display navigational data. If so, then a position is required whereby it is easy to see the screen and manipulate the buttons during flight. The unit is supplied with a dedicated mounting bracket that enables it to be easily removed when required.

4.1 Wiring

All necessary cables and leads (other than a USB cable) are supplied with the unit.

- **Power supply cable** (red +ve, blue -ve)
- **Power and data cable** for connecting external devices such as a PDA or LX 7000...
- **PC cable** with AC/DC power supply for PC communication
- **USB mini B to USB cable**, if USB port will be used for PC communication (not delivery included)

The table below shows the cabling requirements for connection to other devices. When used with the LX 7000/LX 7007, LX 160si and LX 1600, the vario automatically **powers** the Colibri.

	Colibri/LX20-2000 P.and data cable	232 cross	LXIPQ adapter	Cable delivered with LX unit
LX 160	X	X		
LX 160 si				X
LX 1600				X
LX 5000	X	X		
LX 7000				X
PDA			X	

COLIBRI WIRING DIAGRAM

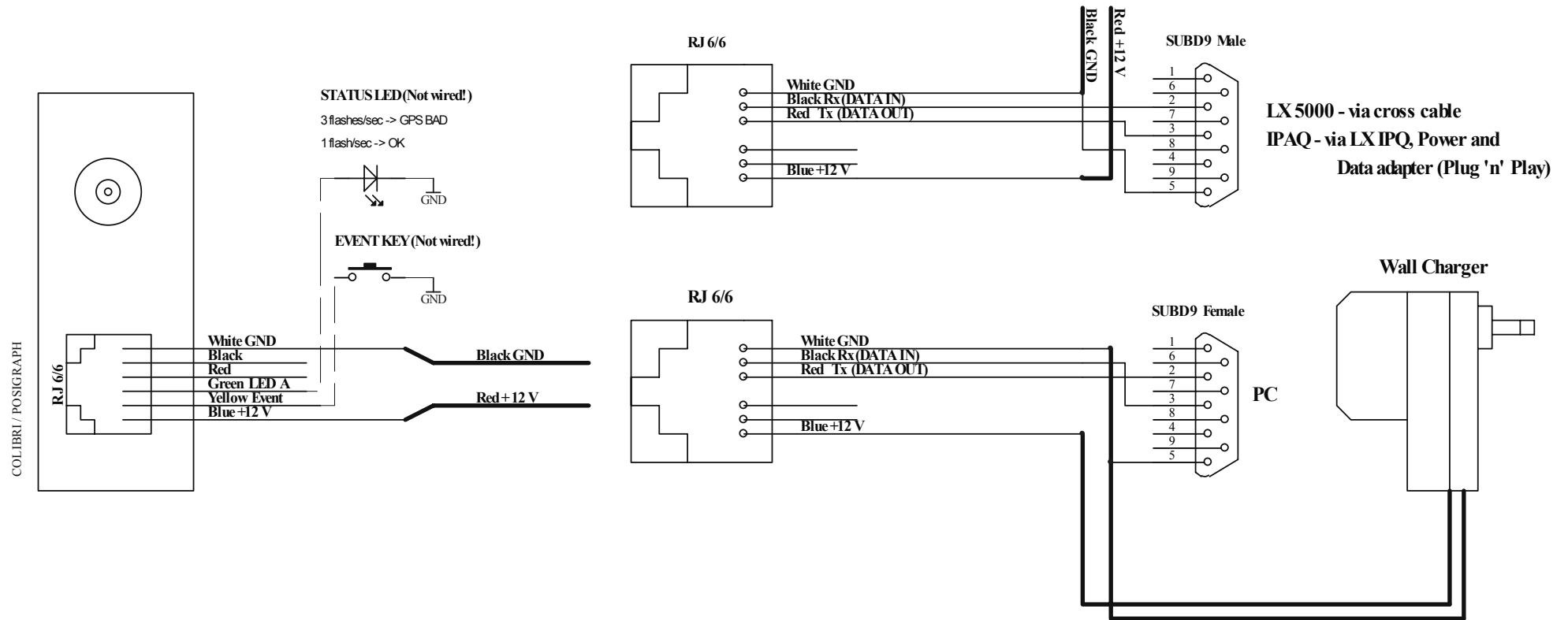

If the unit has been installed in a non visible position, it may be helpful if a remote Event key and LED status indicator are added.

Note!
The unit has no internal fuse, accordingly it is mandatory to fit a 1A external fuse when connecting to the glider power supply, thus preventing any damage to the unit in case of malfunction.

5 Communication

The unit is able to communicate with a:

- PC
- PDA
- LX 5000, LX 7000 or LX 7007

5.1 PC communication

There are many PC analysis programs that are capable of directly communicating with the Colibri such as SeeYou and Strepla. However, the unit is supplied with a PC program, LXe which has been specifically developed to:

- Download **flight records**
- Load the **airport** data base
- Read and write of the **.da4 file**, which contain the TP and tasks
- Read and write of **Flight information** files which contain the pilot, glider and task declaration
- Read and write B and K record **settings**, NMEA output settings, and the UTC offset
- Read and write the configuration of start, turn point and finish **zones**

Note!

Never try to load airspace data into Colibri.

LXe is supplied on the included CD or the latest version can be downloaded from www.lxnavigation.si.

5.1.1 PC specifications

The recommended minimum system configuration is:

Pentium 166MMX or better, running under Windows 95/98/ Me/2000/XP
32MB RAM
Display 1024 x 768 resolution, 16 bit color
20MB free hard disk space (without map)

If the computer has a lower specification than the above, then it is likely that problems will be experienced.

5.1.1.1 Use of laptops

Some modern laptops are not supplied with a dedicated 232 Com port. If this is the case, then one possibility is to use an external USB to Com port adaptor. However, the Colibri has a built in 232 to USB converter that terminates in a Mini Type B USB connector on the bottom side of the unit. This port offers direct connection to a laptop USB port. When connected to the laptop, the laptop will also power the Colibri from the USB port. See chapter 8 for full details.

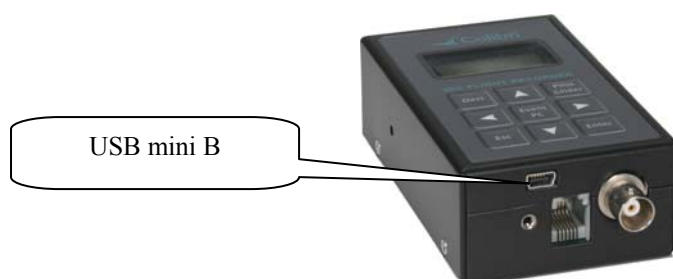

5.1.1.2 Establishing CONNECT status

- When the PC is connected to the Colibri, the two units will connect automatically. This status is confirmed by the Colibri displaying the message CONNECT and making a series of short “beeps”. Further information is contained in the LXe manual which is available on the supplied CD or from the LX website, www.lxnavigation.si.
- When the LX5000/7000 is connected to the Colibri, it is first necessary to select TRANSFER on the LX and then press the PC/EVENT button on the Colibri. Once again, connection is indicated by both the LX and Colibri displaying CONNECT and a series of “beeps” from the Colibri.

5.1.1.2.1 Help - If no Connection is established

- Available communication ports in LXE (Setup→Comm. Port)

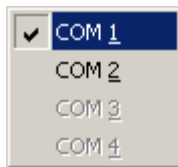

The available serial Com ports will be indicated by highlighted square buttons. The tick in the square indicates the selected Com port for communication with the connected device. Com port selection is not automatic and the correct Com port should be selected by ticking the appropriate box when LXe is first run.

- No ports available



If this message is displayed, then no communication is possible until a Com port has been released.

Reasons for this message include:

- **The PC has no serial ports.** This situation is likely with a Laptop having USB ports only. The solution is to either use an USB to RS232 adaptor which is available from most computer shops, or to use the Colibri USB port. If an adaptor is used, it will be necessary to install a driver.
- The serial ports are occupied by another application. The most likely culprit is ActiSync which tends to grab and retain a serial port connection. If this is suspected, then enter ActiSync and release the serial com port (see below).

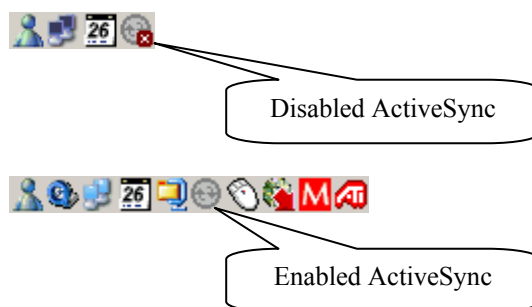

- **How to disable Active Sync ?**

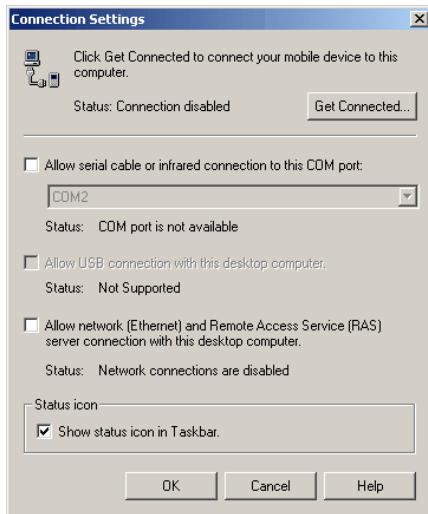

Do a right mouse click on the ActiveSync symbol in the task bar, choose *Connection settings* and disable the serial port. (This is only necessary with PCs having a single com port).

Problems caused by USB to 232 adaptors.

Normally a PC has more than one USB port. On first use of USB/232 adapter, the operating system will detect new USB device and the Wizard will guide you through the setup process to load the driver for specified USB/232 adaptor. After successfully installation of USB/232 driver, LXe will detect a new additional com port. Usually the number of new com port is higher than 4 such as Com 5 or Com 6.

It is recommended that the same physical USB port on PC is always used with the 232/USB adaptor. If you use another USB port, a new installation of the USB/232 driver will be necessary, and the operating system will allocate the next free com port.

The recommended LXe settings for safe and effective communication are:

- Use a fixed baud rate
- Use 19200 bps
- Keep the Colibri connected during preparation....

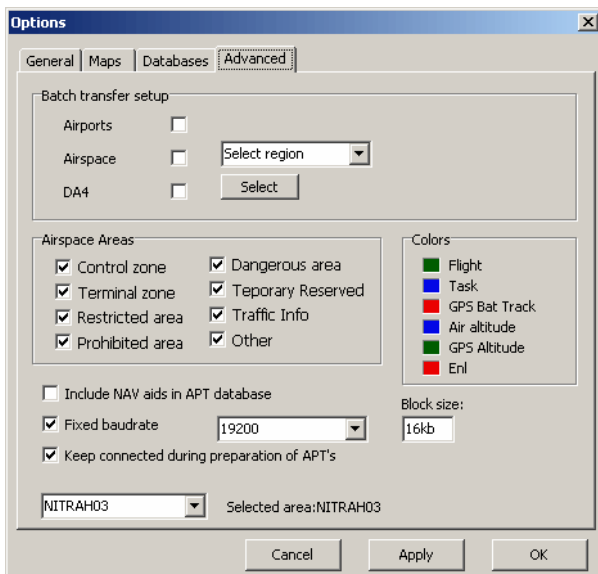

- If problems are experienced downloading flights, after the selected flight has been highlighted, and the following symptoms are experienced;

Symptoms:

- Baud rate is not constant (oscillating from 0k to 19k)
- Many retries at downloading blocks

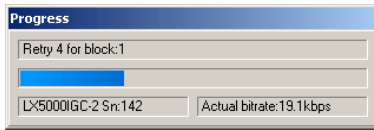

Possible Workaround:

- Reduce communication speed in both the Colibri and the LXe to 9600 baud or lower. This is a typical problem when using a 232/USB adaptor.
- If the problem persists, then seek help from LX Navigation via their website, using the trouble shooting form at *Help* → *Troubleshooting* in LXe, sending it to support@lxnavigation.si

5.1.1.3 Downloading to a PDA

At present, two PDA programs support communication with the Colibri:

- **ConnectLX**, This is a free ware program available on www.lxnavigation.si. The program is identical to ConnectMe from SeeYou.
- **“Downloader”** from FlyWithCE www.flywithce.com

Both programs support basic communication features, but neither must be used to load airports into the Colibri.

Note!

If a **Colibri, LX1600 and PDA** running **SeeYou Mobile** are used, then it is possible to achieve direct communication the PDA to the Colibri is possible. The LX 1600 will recognize the PDA requests and will connect both units directly.

5.1.1.4 Communication with LX 5000/7000

If a Colibri is connected to a LX 5000/7000/7007, then it is possible to exchange the following data:

- Read and write **TP/TSK** data
- Read and write **Flight information** (declaration, pilot and glider data)

See LX 5000/7000 manual for details.

Note!

The LX 7000/7007 will also power the Colibri at the same time. It is essential that the original cable supplied with the LX 7000 is used as it has certain connections intentionally crossed.

6 Basic flight evaluation

Basic flight evaluation tools are contained in LXe. They include:

- **Data integrity check**
- **Baro trace (Barogram)**
- **ENL trace**
- **Flight trace (Route)**
- **Confirmation check (Confirmation)**
- **IGC file in readable ASCII format**

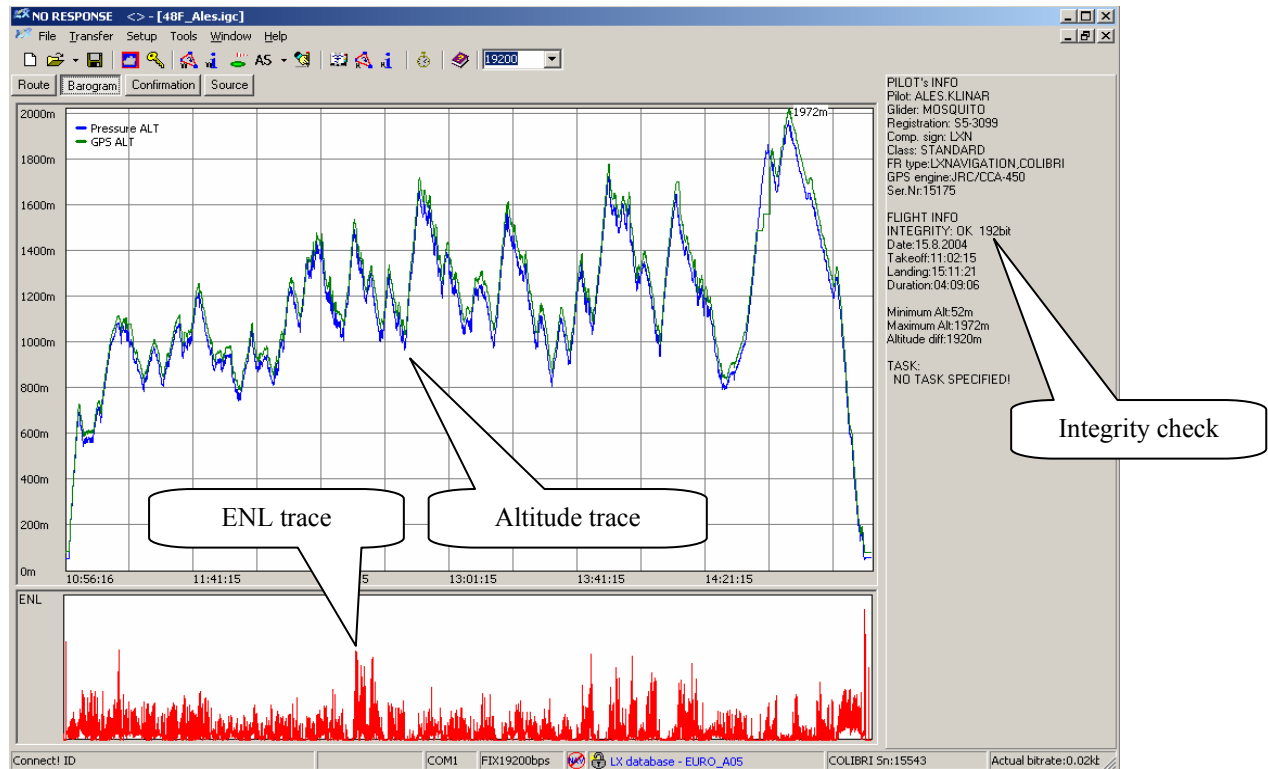

The ENL indication is achieved using of microphone and special band pass filters. While non-powered gliders will produce a specific noise signature, a powered glider will produce a full deflection signal when the engine is operated.

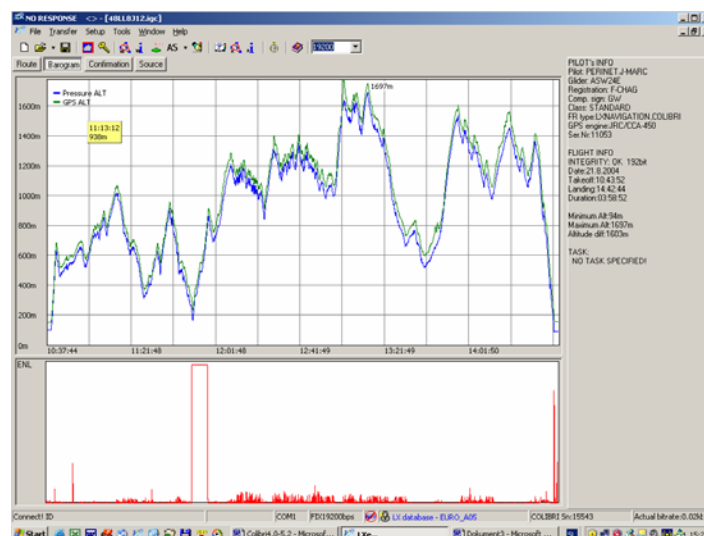

Example of a powered glider ENL trace.

7 Problems

The following problems and messages might be seen.

- If **INIT MEMORY** appears after each power up, the lithium back up battery is defective and should be exchanged by an authorized LX service dealer.
- **Unit 'hangs' during initalisation.** The most likely reason is a corrupted TP/TSK data base. Carry out the INIT MEMORY procedure (see below) and reload the data base. If it happens again, then the TP/TSK database may be corrupt - look for strange characters and glitches. If LXe is used to load the database, it automatically checks for corruption and will not allow it to be loaded if corrupt. However, third party programs may not provide this protection
- **SEAL NOT valid** message informs that the electronic data security seal has operated. If this message is seen in conjunction with the INIT MEMORY message, then the lithium data back up is defective and should be replaced. If the seal defect alone is reported, then a possible reason is the use of third party programs. Both these defects can be repaired by an authorized LX service dealer. An unsealed unit will continue to operate satisfactorily when the ESC button is pressed, but the 'G' record will be missing and any flight records downloaded will fail IGC validation.
- If it is required to delete all flight records stored in the memory, then select '99999' in the **Password** option.

7.1 INIT MEMORY procedure

- Remove power from the Colibri
- Press and hold the ◀ ▶ and **EVENT/PC** buttons
- Power Colibri on
- Release all three buttons
- **INIT MEMORY** will appear for a few seconds
- After using **INIT MEMORY**, all flights, TP/Tasks and APT data will be erased and will require to be reloaded

8 Baro calibration procedure

- Input like pilot name "BARO TEST"(not necessary but recommended)
- Set log time to **1 s**
- put the instrument into baro chamber and switch it on (**antenna not necessary**)
- climb rapidly to apr. **100m** to start recording
- put the baro chamber to 1013,2 HPa and wait one or two minutes to get base line
- start climbing till **1000m** and remain on 1000 m for apr. **30 seconds**
- repeat described procedure till 6000 m or higher
- descend in 1000 m steps till 1013,2 HPa
- open the chamber and switch the unit **off for min 5 minutes**
- Connect the instrument to PC and read the **last flight**
- print out BARO TEST "flight"
- restore log time **to default**
- if a table is necessary, do it manually using LXe/Barogram

Example:

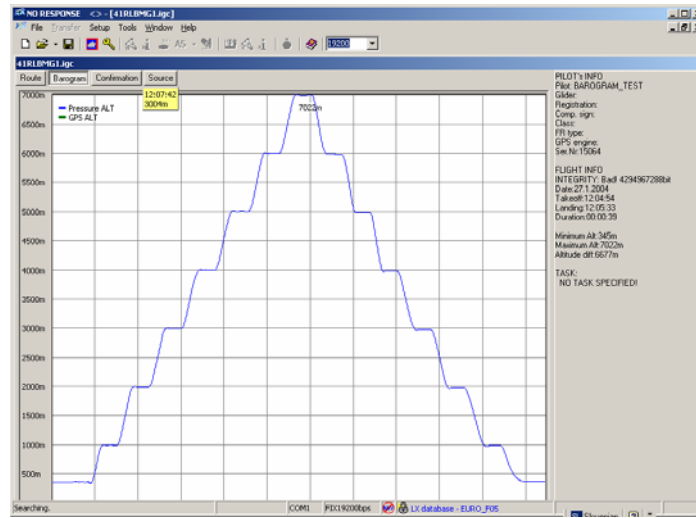

9 Colibri USB Port

9.1 Installing USB driver

When the Colibri is connected using the USB to PC feature for a first time, Windows will detect new hardware.

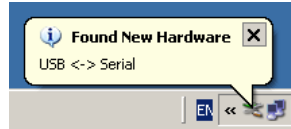

After a few seconds, the installation wizard will appear. Please follow the installation wizard's instructions. If Win 98 is being used, then the installation might not run automatically. In this case the drivers will have to be manually selected from the CDROM.



Be sure that the LXe CD with USB drivers is in the CD tray.

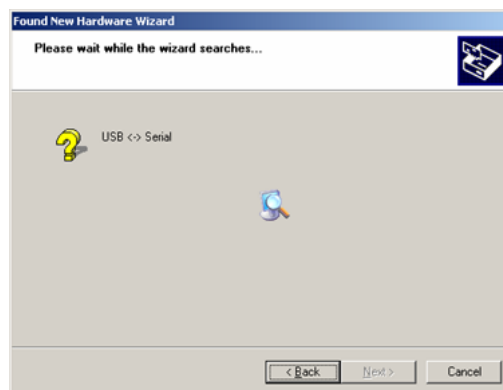

When the wizard finds the correct driver, it will be installed.

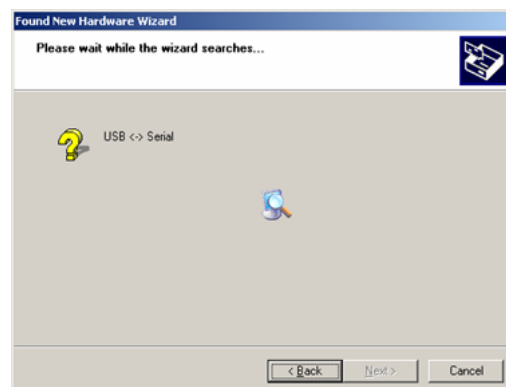
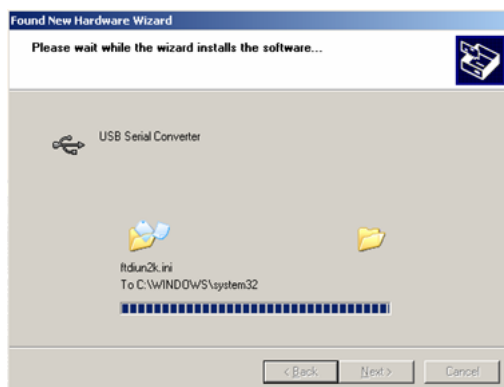

When the USB driver is installed, a new serial port will be detected by the operating system.

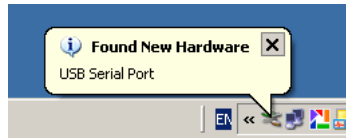

Please, follow the wizard's instructions.

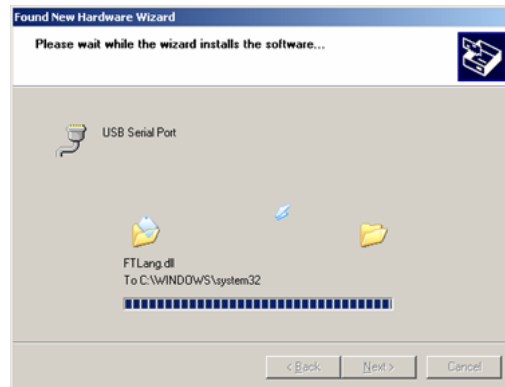
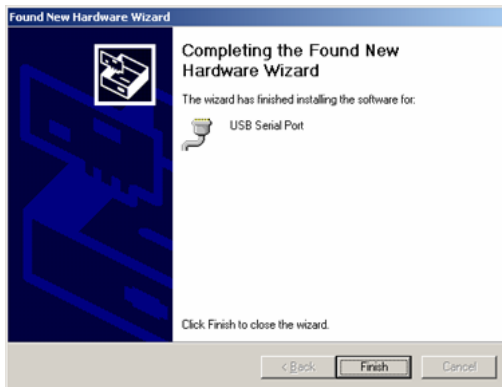

Note!
Additionally help for Win 98 users
www.ftdichip.com
Installation Guides
Utilities Section:
USB View (Shows USB devices)
FTClean (Uninstalls drivers directly without having to use add/remove programs)

9.2 Data transfer through USB

Note!

Always connect the Colibri to the PC with the USB cable, and **then** run LXe. Never do the opposite. When LXe is running, then select the com port.

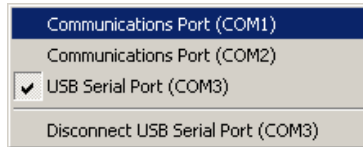

If the same baud rate is selected on the PC and the Colibri, connection will establish automatically. The program is then ready to transfer data between the Colibri and the PC.

Note!

Never disconnect the Colibri from the USB while LXe is running!
To disconnect the Colibri click **“Disconnect USB Serial Port”** or close LXe.

9.3 Troubleshooting the Colibri/USB connection

The Colibri/USB port is not shown in the LXe program.

- Please check to ensure you have the latest version of LXe
- Check that the USB driver is installed properly. (Control Panel – System – Hardware – Device manager)

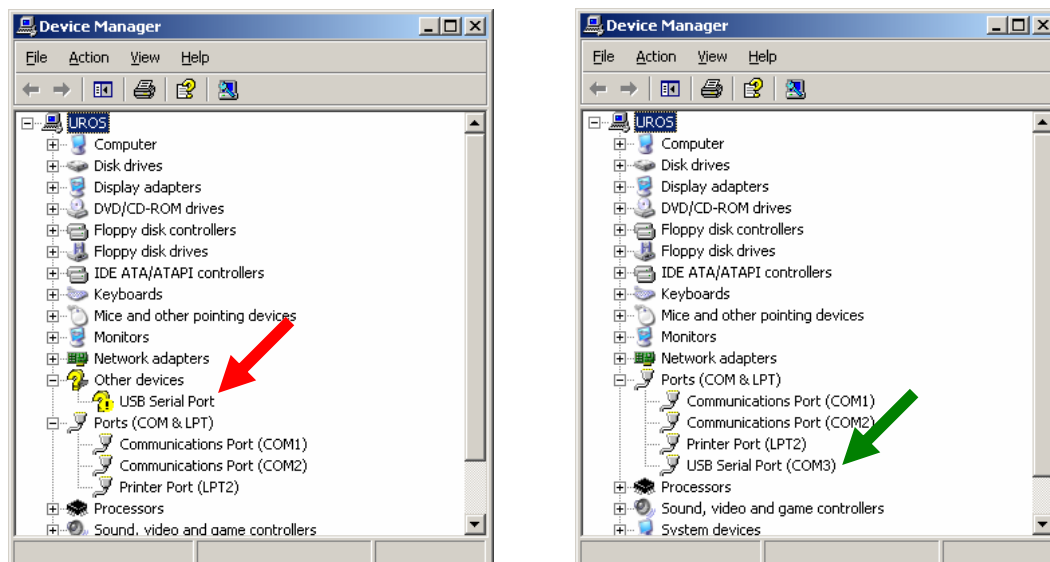

On the left panel the USB Serial port is not installed; on the right panel the serial port is correctly installed.

If Windows cannot find a driver for the USB serial port.

- Please check to ensure that your LXe CD has a USB Drivers folder.
- Let Windows search for a driver on the internet.

10 Tree structure diagram

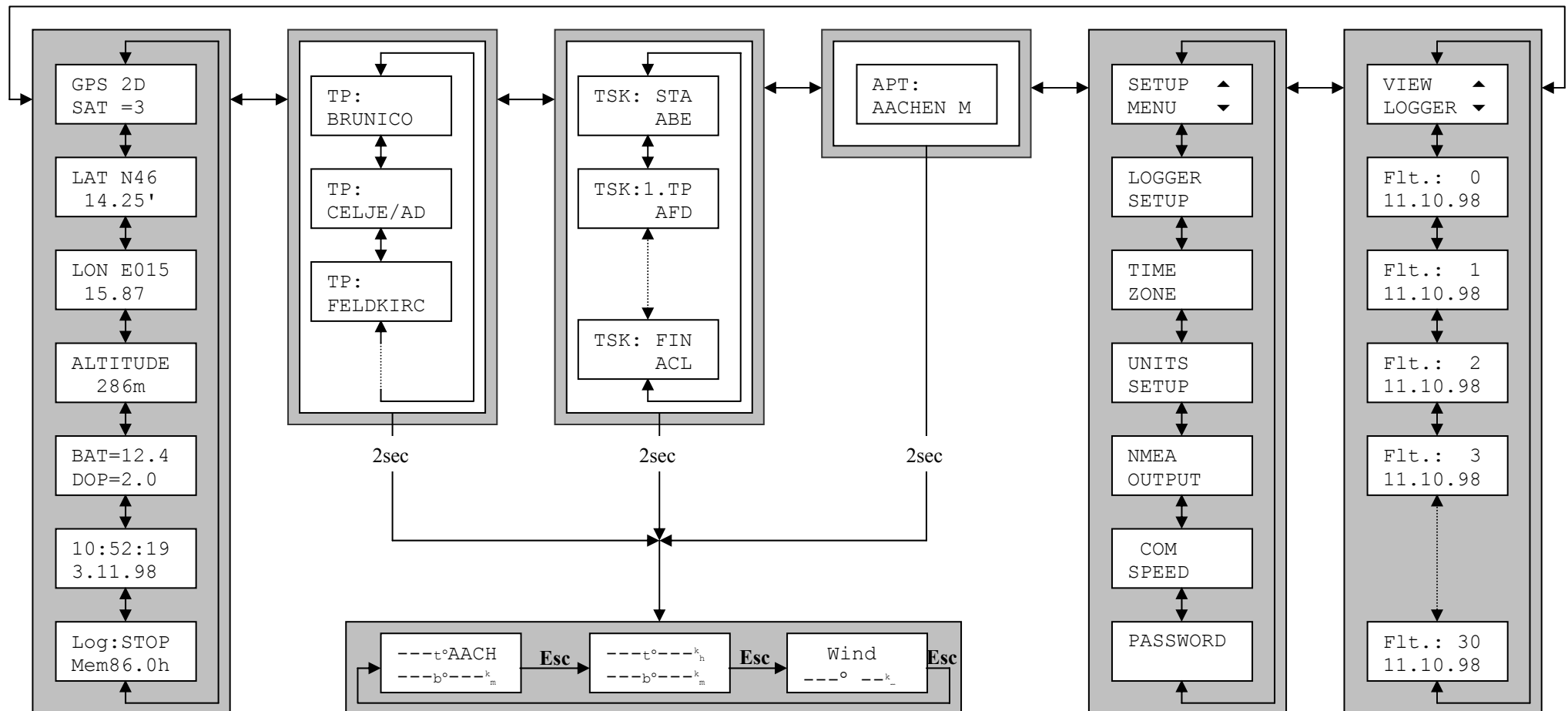

Decl

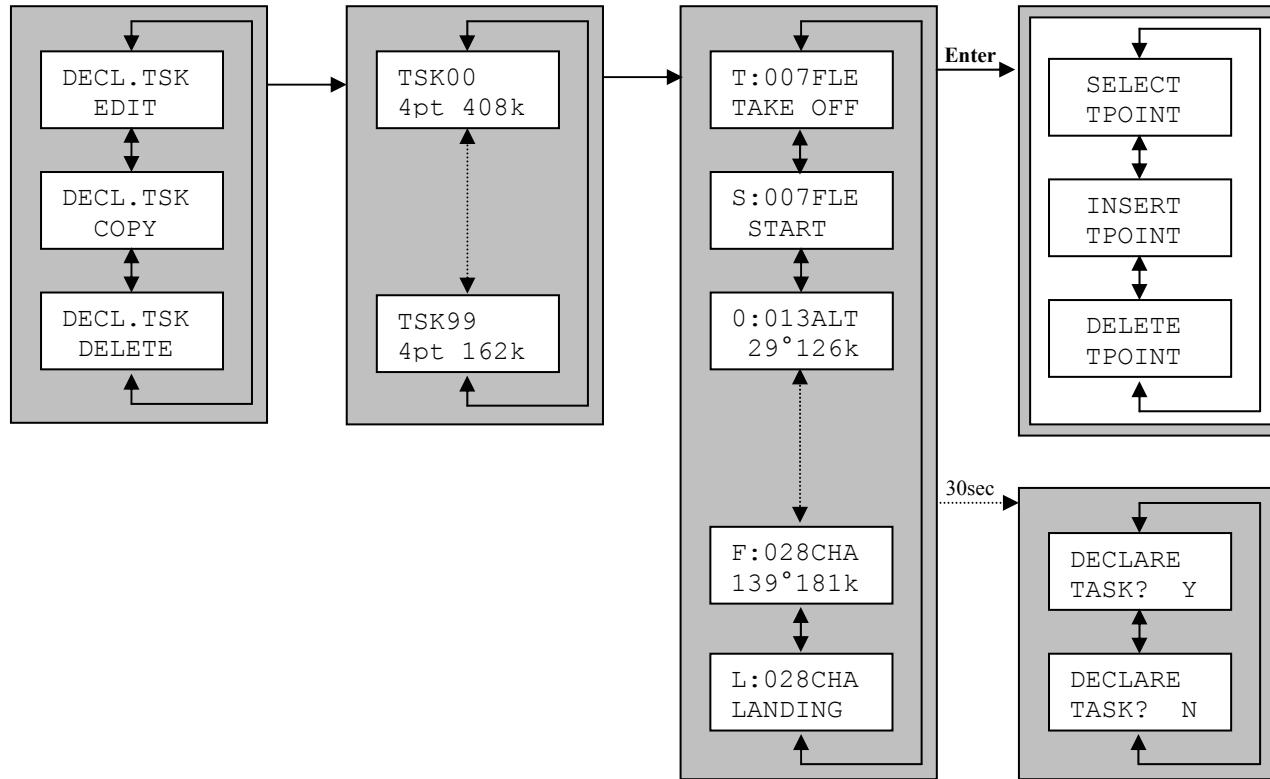

**Pilot
Glider**

